

BALANCE MAX LOAD

Note: maximum weight load on bottom Spikes (spikes closest to the floor) should not exceed 400kg

Equipment situated right on top of corner pillars

max load 180 kg (397lb)

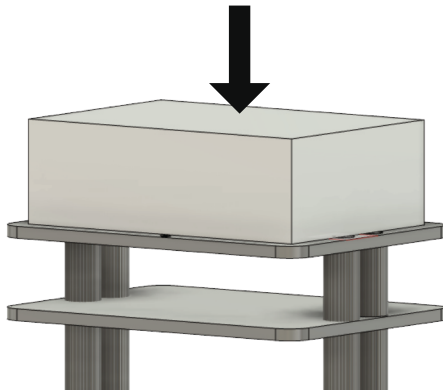

Equipment situated 10 cm (4 in) from corner pillars

max load 150 kg (330lb)

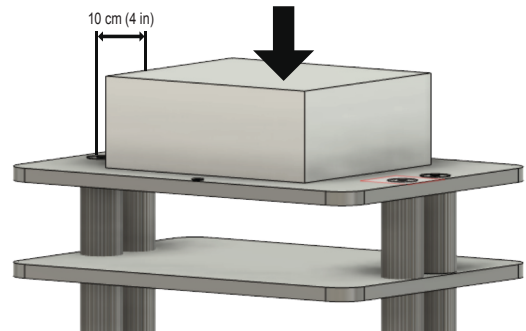

Equipment situated 20 cm (8 in) from corner pillars

max load 100 kg (220lb)

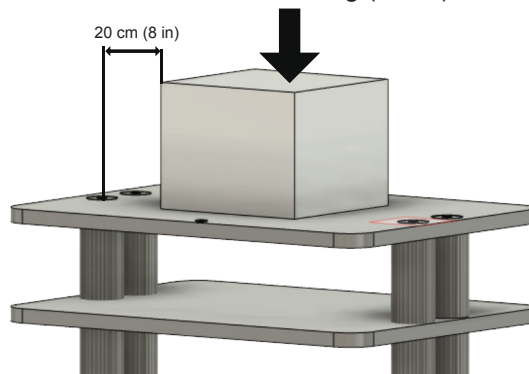

Balance Iso

max load 100 kg (220lb)

